

Hitachi Technical Servers for HPC

Enterprise Server Division
Hitachi, Ltd.

HITACHI
Inspire the Next

1.1

Three Policies for HPC

1. High Performance / Efficiency on Single Node

2. High Scalability

Cluster system and Parallel system

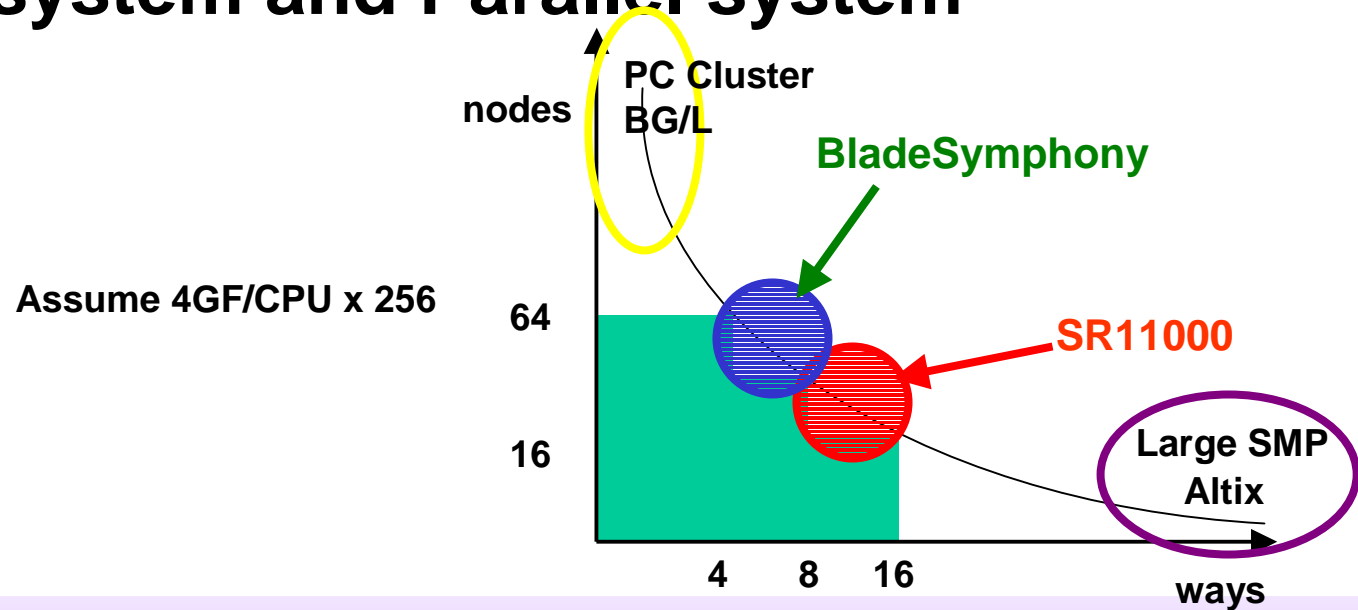

3. Customer Satisfaction

1.2

HITACHI's HPC systems

Almost 30 Years of Super Computing Development

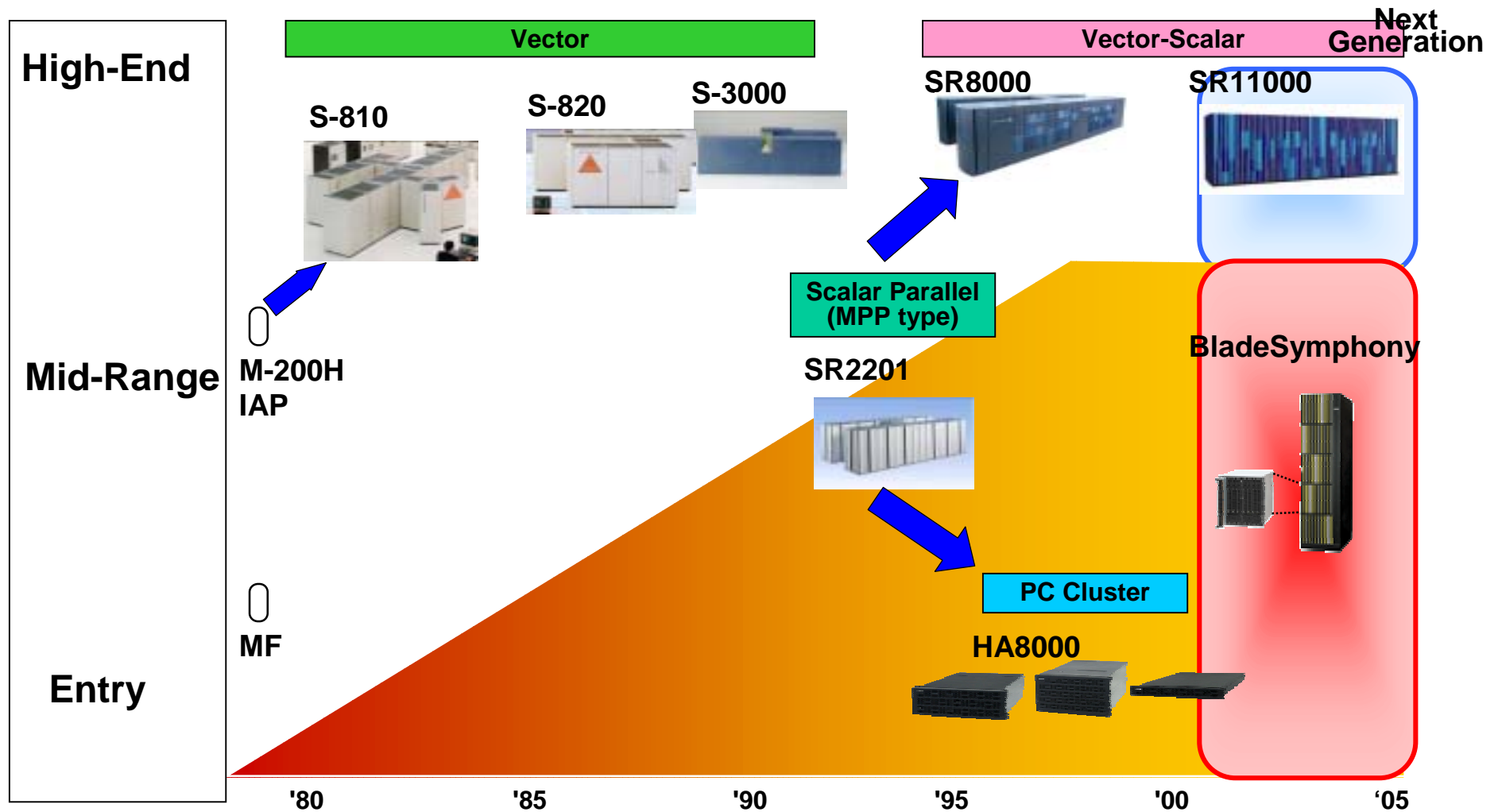

2. Super Technical Server SR11000

2.1

SR11000 product highlights

(1) High Performance on a Single Node

Pseudo Vector Processing feature

COMPAS feature

(COMPAS: Co-operative Micro-Processors in single Address Space)

High Memory Throughput with 16 way SMP

(2) High Scalability

High-Speed inter-node network

(3) Hitachi Proprietary Compilers and Libraries

Automatically Parallelizing Compiler

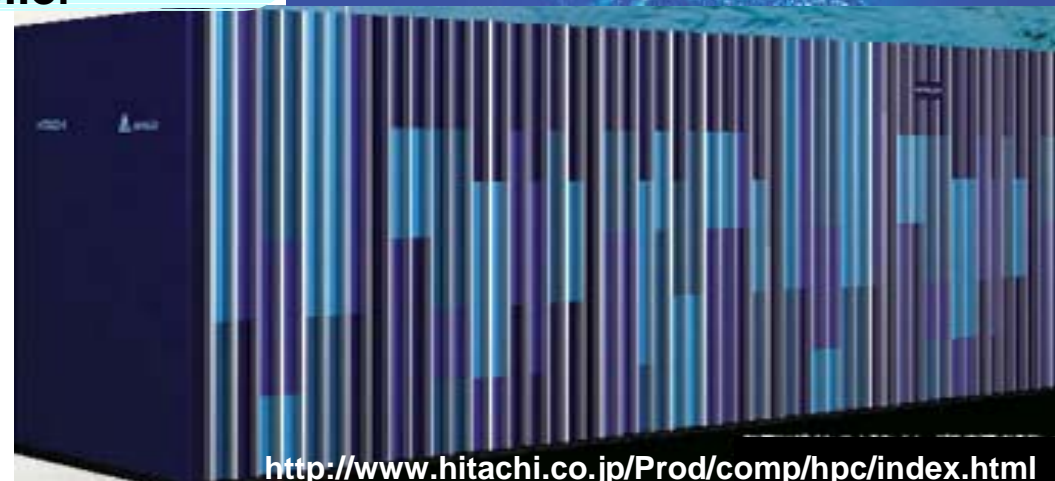
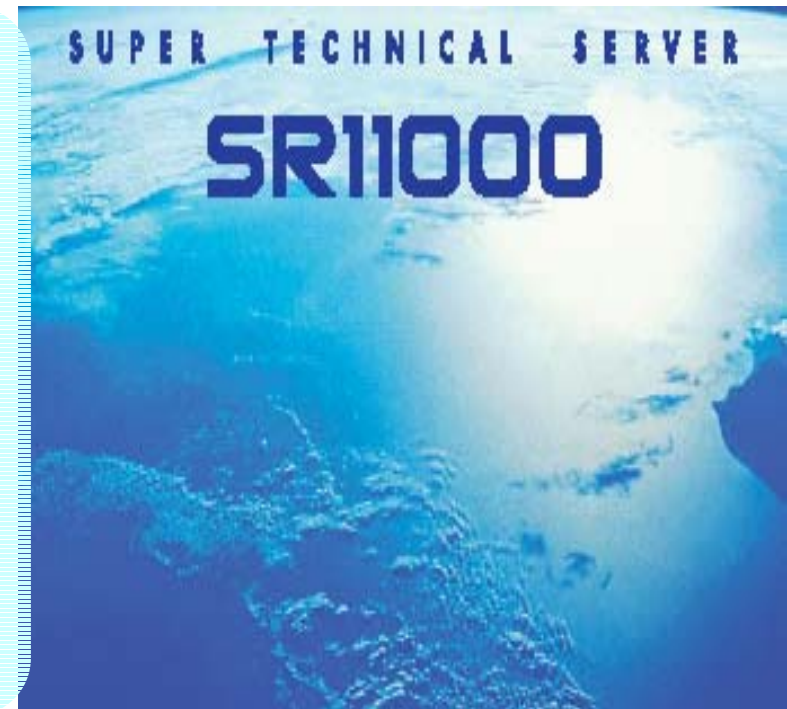

2.2

Performance Improvement SR11000 $H1 < J1 < K1$

System theoretical peak performance (TFLOPS)	68.8
Maximum Number of Nodes	512
Maximum Memory Capacity / Node (GB)	128
Node Peak Performance (GFLOPS)	134.4
Ways / Node	16
Inter-Node Network Throughput (GB/s / Node)	4 / 8 / 12 x 2

Just Announced!
Oct. 5, 2005
LINPACK TPP
8.9TFlops @ 80 nodes

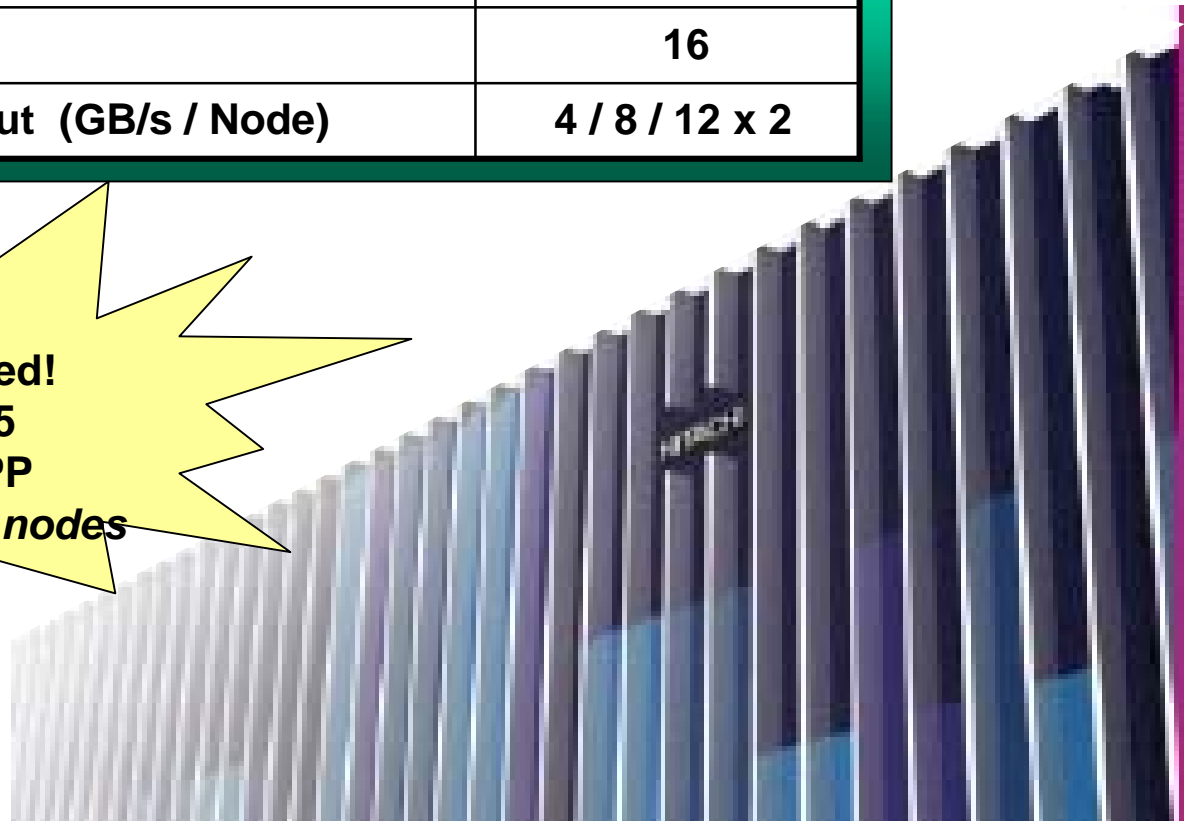

2.3

Hitachi's customers and their research fields

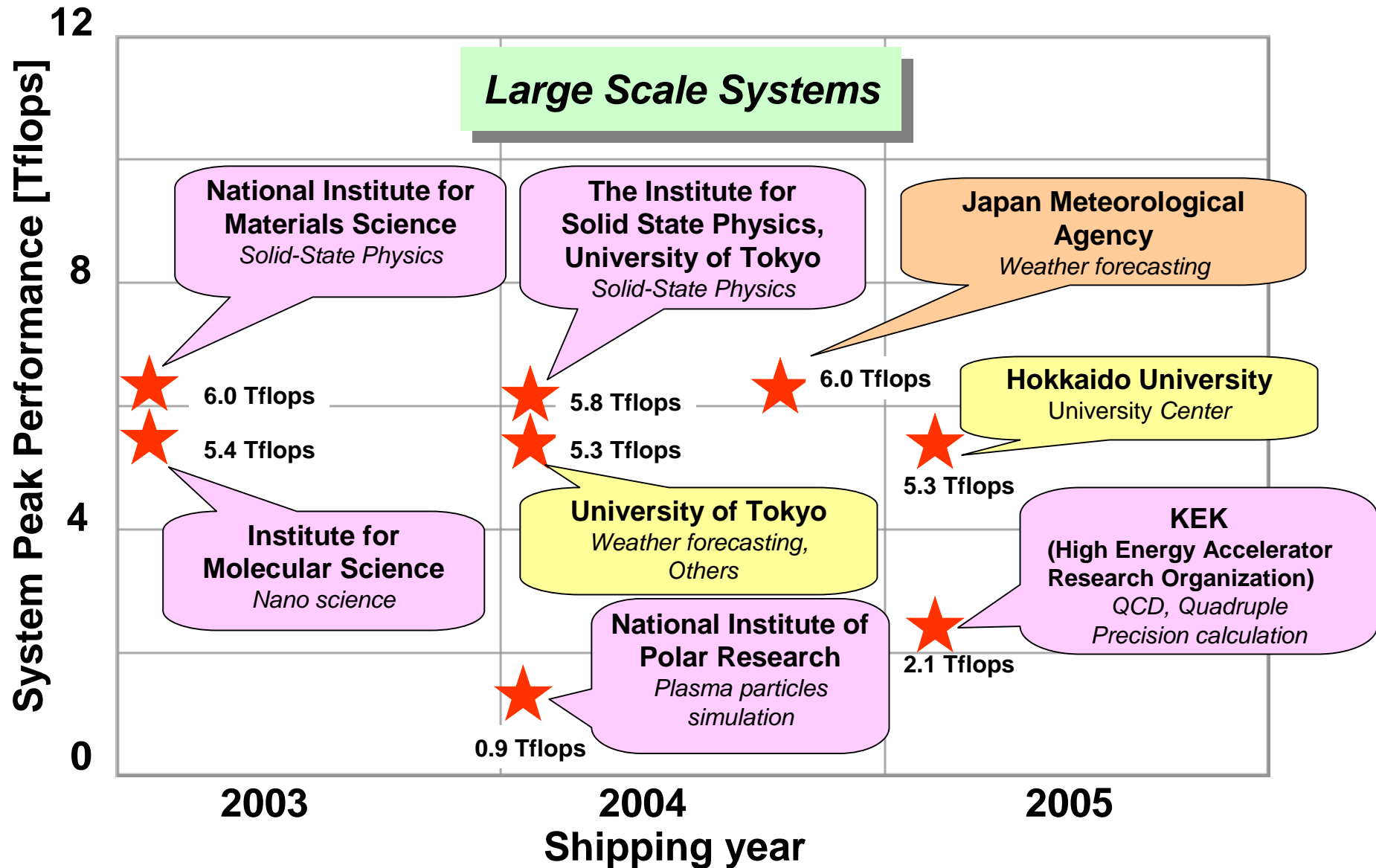

3. BladeSymphony

A New Approach to the HPC Area

Unified Blade Platform “BladeSymphony”

✓ *Server Blade*

- IPF Blades and IA32 Blades can be mixed in the same Server Chassis
- Industry-first “SMP interconnect” among Server Modules for IPF

✓ *Storage*

✓ *Network - InfiniBand*

**Manage entire server, network,
and storage system**



3.2

BladeSymphony: Technology of the essence

High Performance

- ✓ **Performance oriented IPF Blade**
Front Side Bus speeds of 667MHz

Flexibly Extensible

- ✓ **Itanium2-based scalable to 8-way SMP**

High Availability

- ✓ **Scalability UP and OUT**

Customer Satisfaction

- ✓ **N + M system configuration**
Fully Redundant Server Blade Design

- ✓ **Support**



3.3

Application Areas

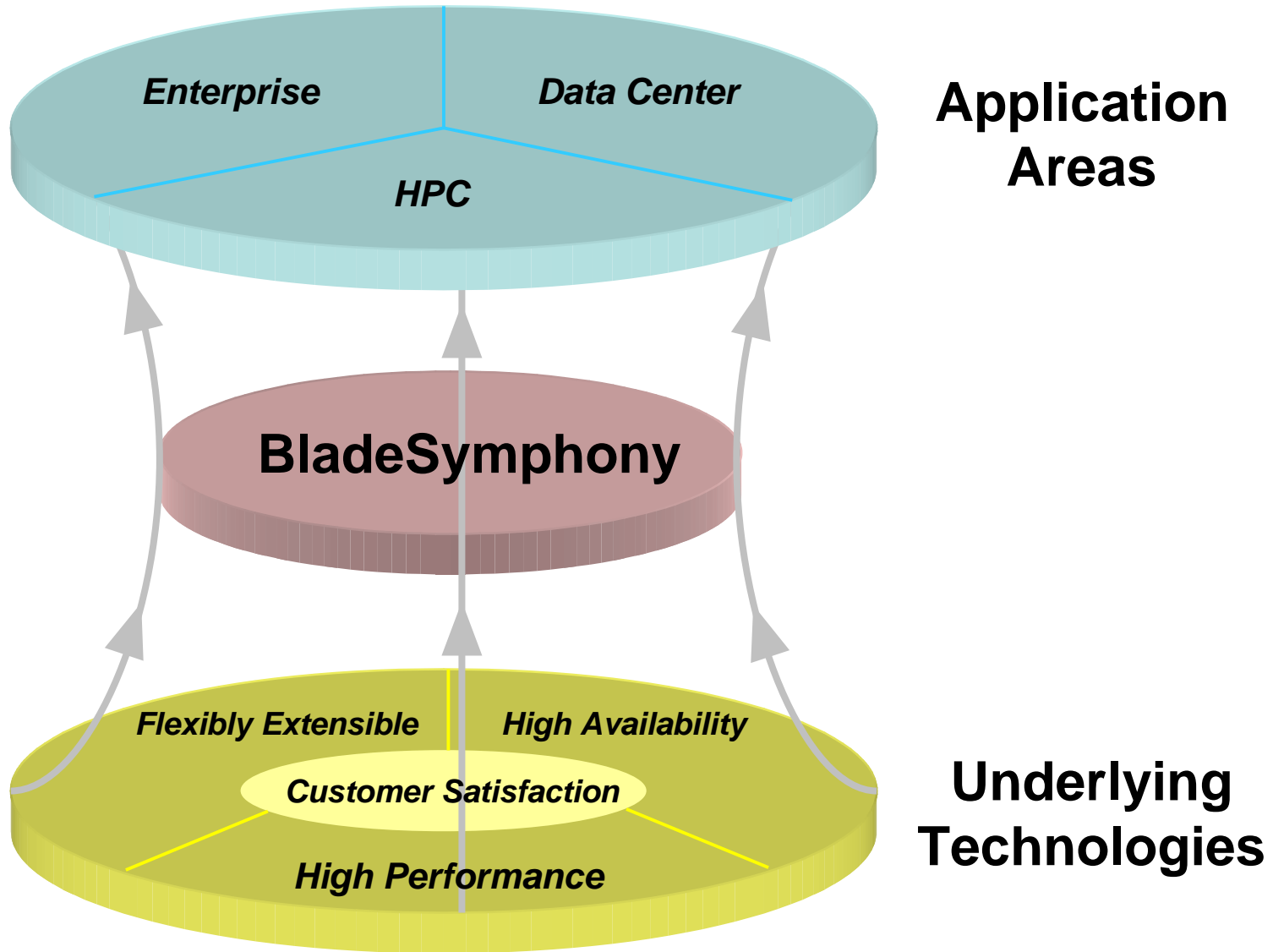

3.4

Example in the Commercial Area - Finance

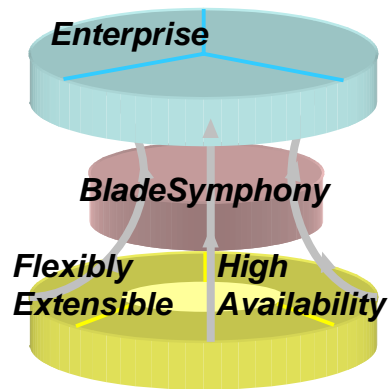

Citrix MetaFrame and BladeSymphony

•Benefits

- Increased efficiency of administration work
- Provides firm security environment
- 50 Users per Blade capability
- Can utilize BladeSymphony's scale-out model when user numbers increase in the future

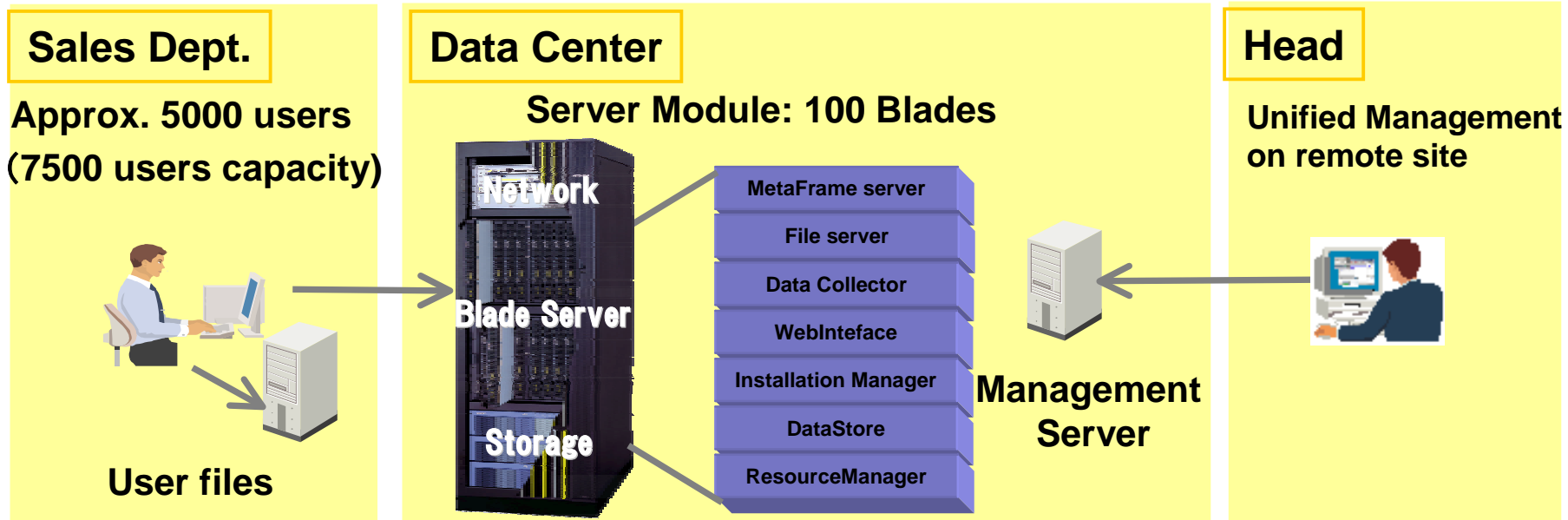

Corresponds to all accesses such as Web access, remote access, and access to legacy systems.

3.5

Example of an Online Game Solution

BladeSymphony is introduced by Hanbit Ubiquitous Entertainment Co.,Ltd.

“Granado Espada” High Quality MMORPG (2006 Coming Soon!)



(c)2003-2005 IMC Games Co.,Ltd./ Published by Hanbit Ubiquitous Entertainment Co.,Ltd.

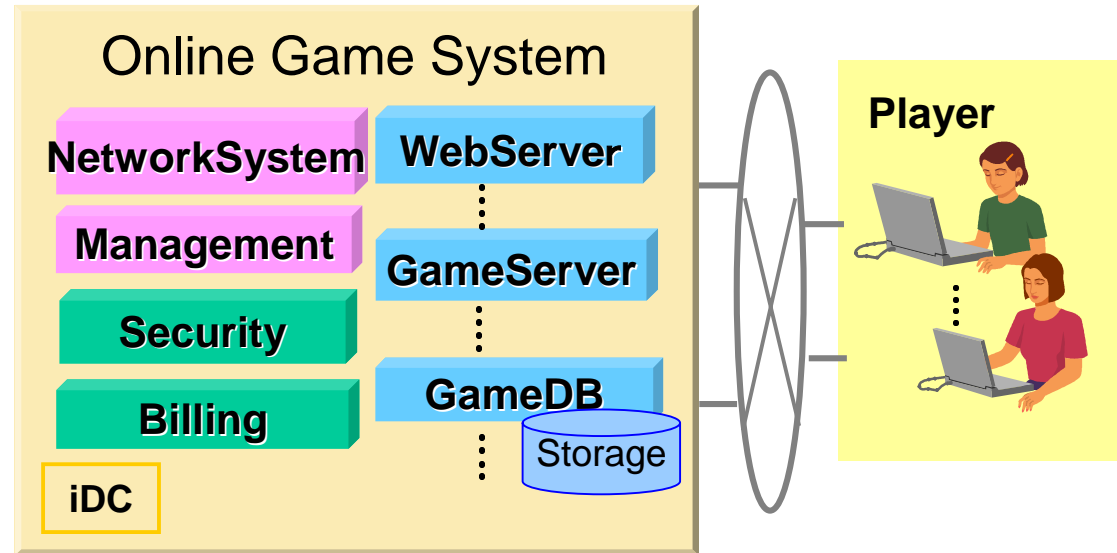

BladeSymphony was selected as the first Japanese closed beta test server “Primero” for a popular game software 『Granado Espada』

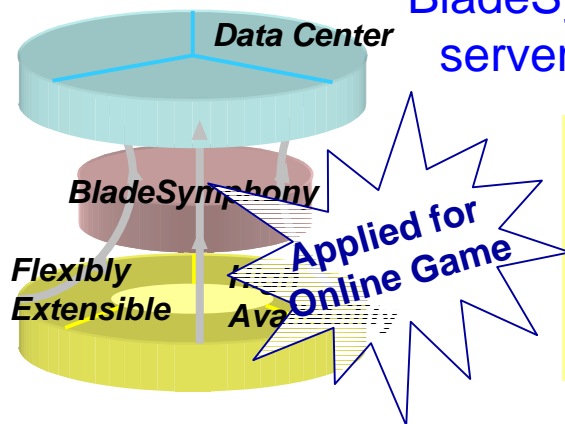

- High Performance Processor
- System extensibility
- Non stop operation, 24 hours 365 days
- Easy management for server access, network load balance

3.6

HPC Relevant BladeSymphony Design Points

1. High Performance on a Single Node

2. High Memory Bandwidth,
Low Latency with FSB 667MHz

3. High-speed Network Switch: InfiniBand

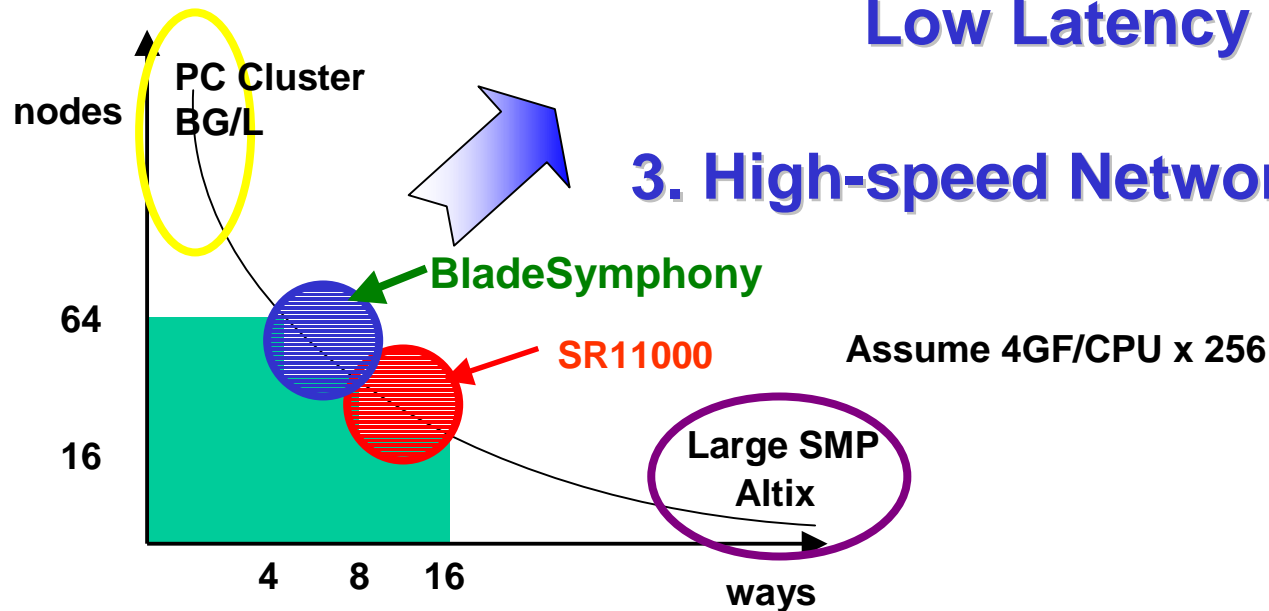

4. I/O Flexibility and Bandwidth Capacity – PCI-Express

3.7

High Performance IPF Blade

- Up to 8-way SMP
- Up to 16 PCI-X Slots at 8-way
- High Speed data transfer
 - Memory : 42.7GB/s (8way)
 - I/O : 24GB/s (8way)
- 128GB of Memory (at 8way, 2GB DDR2-DIMM)

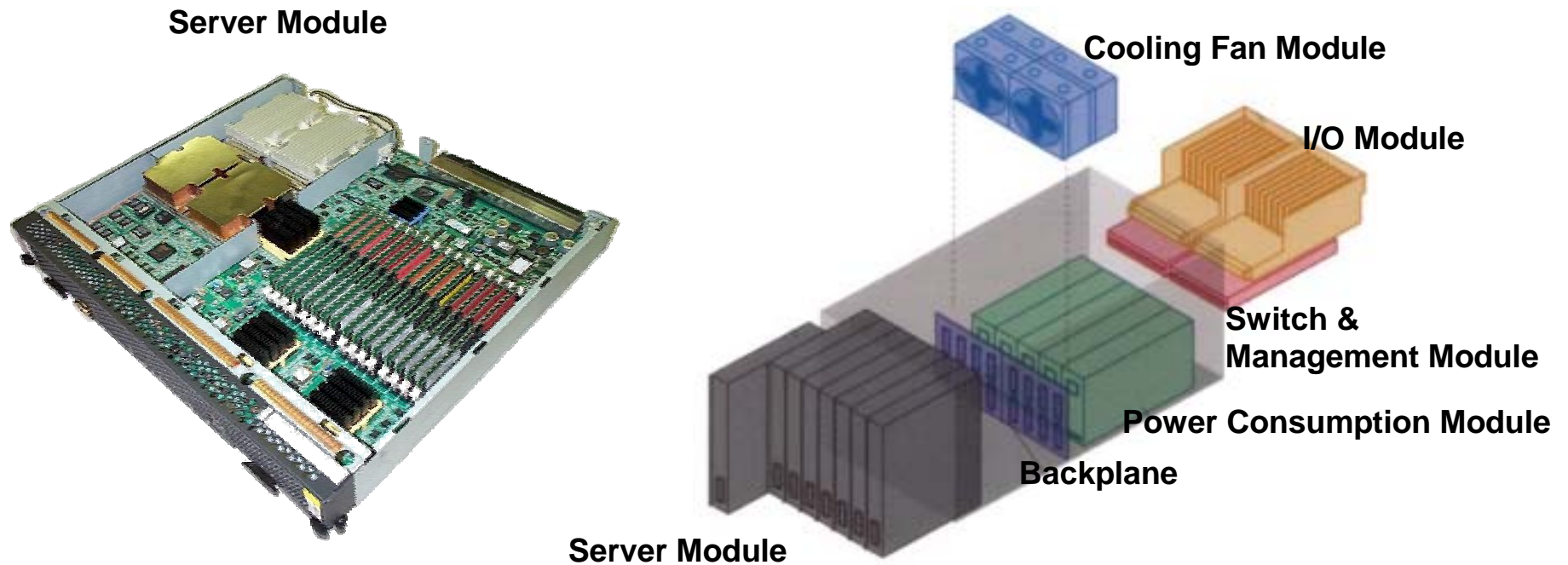

3.8

World Best Performance* Itanium[®]2 Server

World Best Performance*
SPECfp2000
Benchmark

FSB 667MHz Itanium[®]2 Server

- Hitachi Original Chipset: FSB 667MHz Itanium2 Processor
- High Memory Throughput, High Speed Module link (8-way SMP)

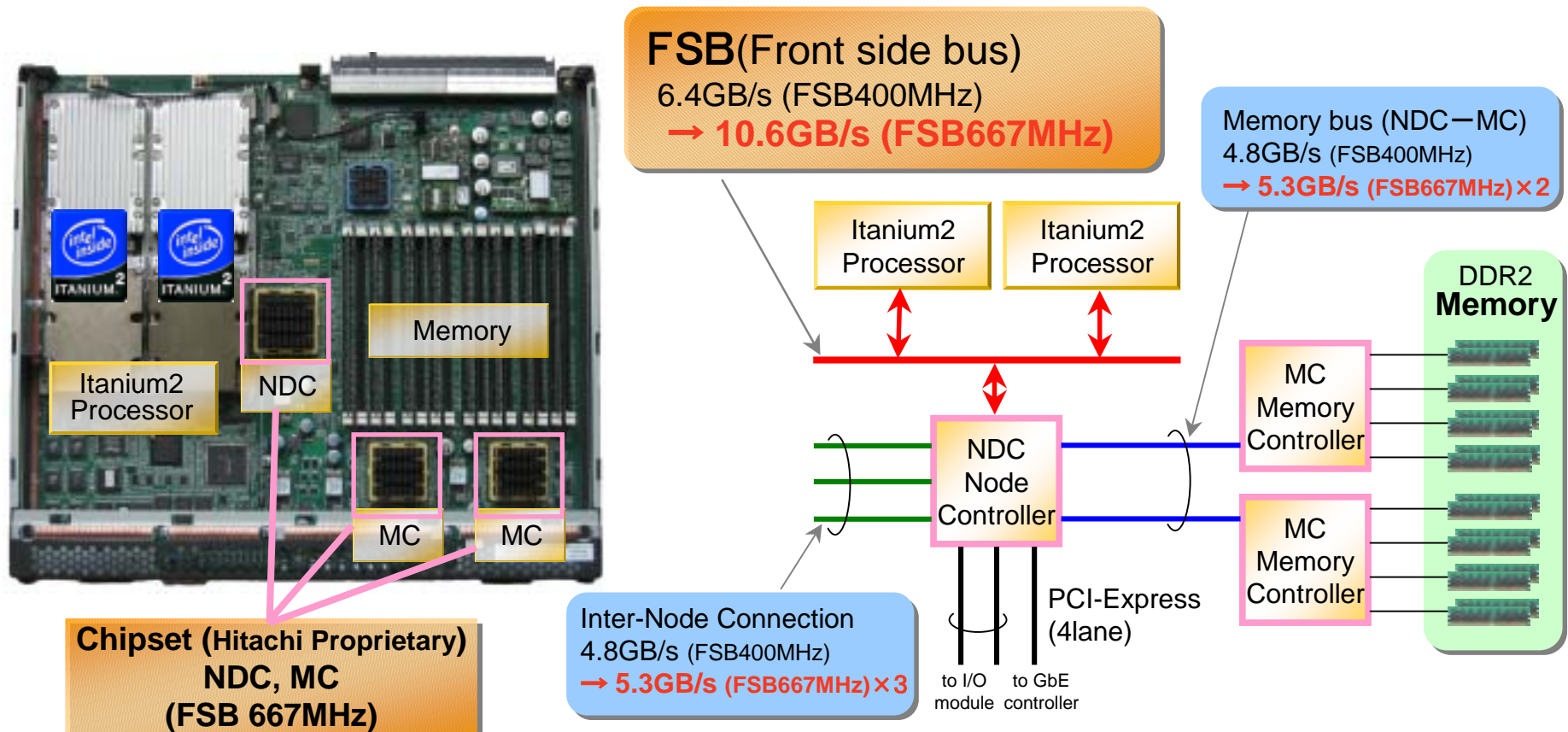

* As of July 19, 2005

3.9

Benchmark Performance

STREAM

Good Scalability
with FSB667MHz

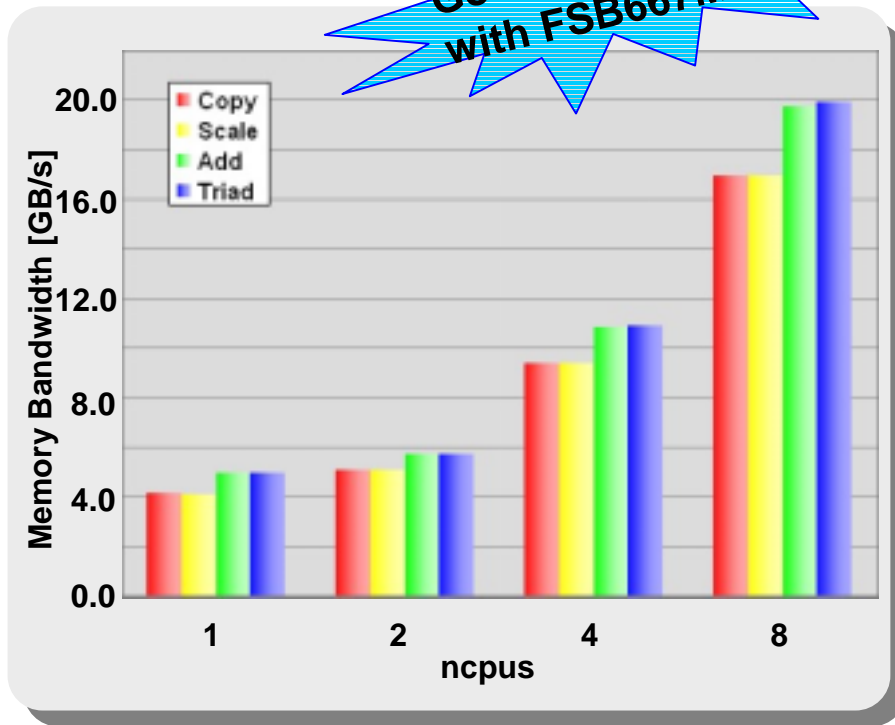

LINPACK

Top Performance
with Itanium2

Dimension: $N = 25,000$

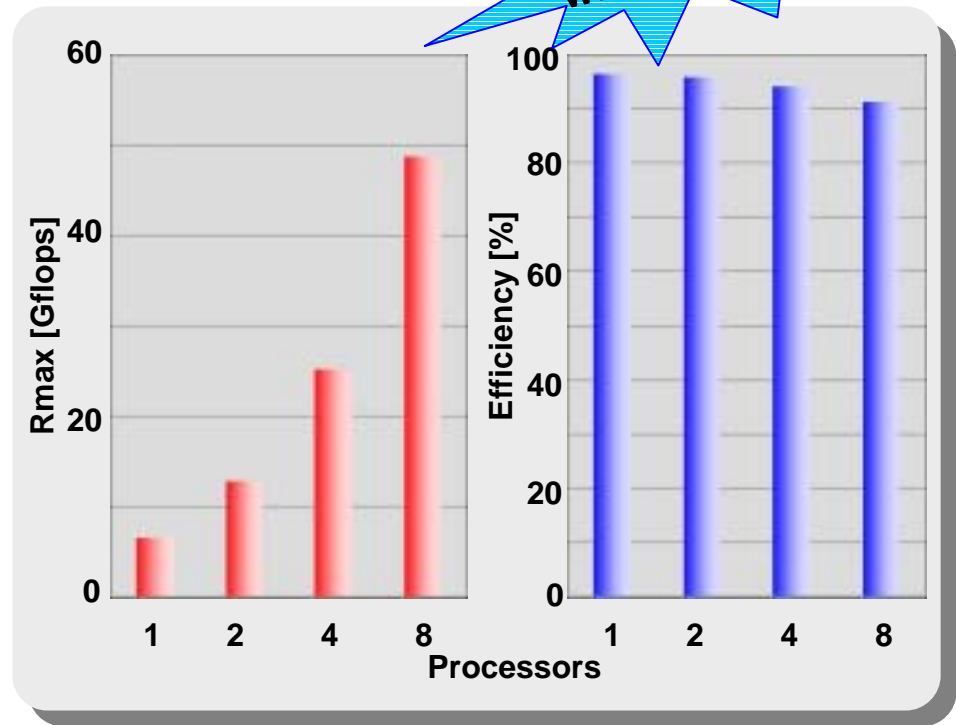

High Efficiency with 8-way SMP

Hitachi BladeSymphony (1.66GHz, 9M, 667MHz FSBz)

HITACHI
Inspire the Next